

# Comparison of High Boost Ratio Hybrid Transformer DC-DC Converter with Multistage Converter

Soedibyo<sup>1</sup>, Sjamsjul Anam<sup>2</sup>

Electrical Engineering Department  
Institut Teknologi Sepuluh Nopember  
Surabaya, Indonesia  
dibyosoe@gmail.com<sup>1</sup>, anam@ee.its.ac.id<sup>2</sup>

**Abstract**—Energy of Photovoltaic is one of energy resource that potential to be developed in Indonesia. Output power of Photovoltaic is changing according to changes of sun irradiance. Energy sources that produce DC low voltage require a step-up converter to increase the voltage before it is converted into AC voltage. To optimize the system, step-up converters must have a high voltage ratio and high efficiency at all of loading level and wide voltage input range. In this research will be compared between multistage converter and high voltage ratio boost converter that utilizes combination of pulsewidth modulation (PWM) operating mode and a resonant mode. This converter only requires one switch, so it's easier in the controlling. This research results showed with same duty cycle and voltage input, transformer hybrid method can produce power output greater than multistage. The voltage output of hybrid transformer can also achieve steady state faster than using a hybrid converter. So the hybrid converter transformer has the better ability than multistage converter and can be implemented in alternative energy resources that produce a low DC voltage such as photovoltaics.

**Keywords**— Photovoltaic; high voltage ratio boost converter; multistage converter; hybrid transformer.

## I. INTRODUCTION

Photovoltaic is one of the alternative energy resources that can reduce dependence of fossil fuels. Photovoltaic has a high potential to be developed in Indonesia considering the geography is at the equator. Photovoltaic has a low voltage DC output and varies according to changes in sun irradiance. The power generated was also changing. Low DC voltage requires a step-up converter to increase the voltage before it is converted into AC voltage. To optimize the system, the step-up converter should have high voltage ratio in order to can work on a wide voltage input range and has high efficiency at all of load range.

At previous research produced clamp-mode coupled-inductor buck-boost converter [1]. Leakage energy of converter that comes from reprocessed coupled-inductor which leads to reduced losses of the converter. But stress on the diode such as the fly back converter is greater than the DC voltage output. In this converter also has a high ripple currents on the input side.

Multistage Converter is a DC-DC converter modification between conventional boost converter with the use of capacitors switching to obtain a higher voltage output by using

a single switch. Multistage Converter has a huge conversion rate while not using the large duty cycle and without a transformer compared conventional boost converters. The level of converter can be changed without changing the main circuit in the boost converter.

In photovoltaic Applications, the converter should have high voltage ratio and high efficiency to the wide range of load voltage input. Therefore, proposed high-boost ratio hybrid transformer topology by utilizing the hybrid operation mode [4], [5]. Hybrid operating mode is a combination of pulse width modulation (PWM) and a resonant mode.

With the use of hybrid transformer, the energy transfer through a two-state transformer, that's as a common transformer and as a coupled-inductor, so the magnetic component can be used effectively. The continuous input current cause small current ripple than the topology that uses a coupled-inductor. Conduction losses in the transformer is getting smaller due to the reduced value of the RMS current input that passes through the primary of transformer. The voltage stress on the switch is always on a low voltage level and not affected by changes of the voltage input when the voltage output is maintained. turn-off current on the switch is reduced because of the resonance section. With the reduction of the RMS value of current input and a reduced turn-off current on the switch, then the converter has high efficiency at low load. Capacitor resonance make voltage stress on the diode below the voltage output and is not affected by changes of the voltage input when the voltage output is maintained [3]. With this topology obtained a high voltage ratio can work on a wide input voltage range and has high efficiency at all levels of loading.

## II. RESEARCH METHODOLOGY

### A. Multistage Converter Topology

Multistage Converter is a DC-DC converter modification between conventional boost converter with the use of switching capacitors to obtain a higher voltage output by using single switching. Multistage Converter component consists of one inductor (L), 1 switch (S), 2N-1 diode (D) and 2N-1 capacitors (C). N is the number of levels used in multilevel boost converters.

Lowest circuit of Multistage Converter is a conventional boost converter circuit, with C1 voltage is the voltage of the

conventional boost converter. So the voltage output of multistage converter is  $V_{c1} \times N$ .  $N$  is the number of converter levels.

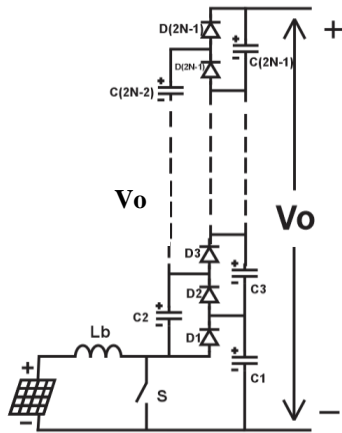

Figure 1. Multistage Converter Topology

If the switch is on, the voltage of the inductor ( $L_b$ ) equal to the voltage input ( $V_i$ ), If the voltage on the capacitor  $C_1$  is greater than  $C_2$  voltage, then  $C_2$  capacitor voltage will increase because the capacitor  $C_2$  charged by the voltage across the capacitor  $C_1$  through  $D_2$  and  $S$ . If the voltage  $C_2 + C_4$  lower than the voltage of  $C_1 + C_5$ , the voltage across the capacitor  $C_2 + C_4$  will increase as charged by the voltage across the capacitor  $C_1 + C_3$  through  $D_4$  and  $S$ . in the same way, the  $C_1$ ,  $C_3$  and  $C_5$  capacitors charge the voltage to the capacitor  $C_2$ ,  $C_4$  and  $C_6$ .

If the switch is off, the inductor current turn on  $D_1$  and cause voltage capacitor  $C_1$  charged. In the same condition, the capacitor  $C_1 + C_3$  will be charged by the voltage of the capacitor  $C_2 + V_i + V_{LB}$  through  $D_3$ . In the same way,  $V_i + V_{LB} + V_{c2} + V_{c4}$  will charge the voltage on the capacitor  $C_1$ ,  $C_3$  and  $C_5$  until the most level voltage charge. voltage output level is also affected by the duty cycle ( $D$ ). Duty cycle is the ratio between the time at on ( $t_{on}$ ) and switching period ( $T$ ).

$$D = \frac{t_{on}}{T} \quad (1)$$

$$T = t_{on} + t_{off} \quad (2)$$

Maka didapat :

$$t_{on} = D.T \quad (3)$$

$$t_{off} = (1-D).T \quad (4)$$

With the assumption that current through inductor is constant, then obtained equation at time at on condition ( $t_{on}$ ) following:

$$\Delta i(t_{on}) = \frac{V_i(D.T)}{L_b} \quad (5)$$

$$L = \frac{V_i(D.T)}{\Delta i(t_{on})} = \frac{V_i(D)}{\Delta i(t_{on}).f} \quad (6)$$

Sedangkan pada saat keadaan  $t_{off}$ :

$$\Delta i(t_{off}) = \frac{(V_{c1}-V_i).(1-D).T}{L_b} \quad (7)$$

$$\Delta i(t_{on}) = \Delta i(t_{off})$$

$$\frac{V_i(D.T)}{L_b} = \frac{(V_{c1}-V_i).(1-D).T}{L_b}$$

$$V_{c1} = \frac{V_i}{(1-D)} \quad (8)$$

The equation of voltage output is following:

$$V_o = V_{c1} + V_{c3} + V_{c5} + V_{c7} \quad (9)$$

$$V_o = N.V_{c1} \quad (10)$$

$$V_o = \frac{N.V_i}{(1-D)} \quad (11)$$

So, Gain obtained:

$$G = \frac{V_o}{V_i} = \frac{N}{(1-D)} \quad (12)$$

To get the capacitance value of each capacitor is:

$$C = \frac{V_o.D.N}{R.(\Delta V_o).f} \quad (13)$$

### B. Boost Converter with Hybrid Transformator Topology

Boost converter with a hybrid transformer is circuit circuit to increase voltage with the ratio of input and output voltage is high enough. This converter uses a hybrid transformer, inductor resonance and three diodes as clamping diode, diode resonance and output diode, a switch, four capacitors as capacitor input, clamping capacitors, resonance capacitor and capacitors output[1]. This converter circuit topology as shown in Figure 1.

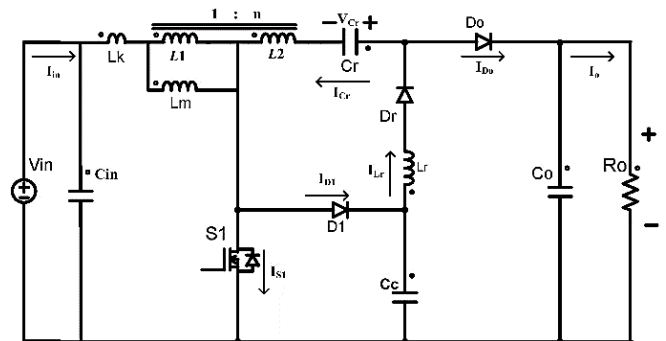

Figure 2. Boost Converter with Hybrid Transformer Topology

Capacitor input ( $C_{in}$ ) is used to reduce ripple of the voltage input. Hybrid transformer (HT) modeled using the ideal transformer with magnetizing inductance include ( $L_m$ ) and leak inductance ( $L_k$ ) on the primary of the transformer. Hybrid transformer turns ratio is 1: n. Switch ( $S_1$ ) is a metal oxide semiconductor field effect transistor (MOSFET). Clamping diode ( $D_1$ ) is a clamping diode that serves as the trajectory of energy from leaking inductance originating from hybrid transformer when the switch is off. Resonance diodes ( $D_r$ ) used in order to the current flow is in one direction when the circuit is in resonance mode, when the charging process energy at resonance capacitor ( $C_r$ ).  $D_o$  is diode output that on track to transfer energy to the output side. The capacitor output ( $C_o$ ) as a filter to reduce ripple voltage on the output side.  $R_o$  is the resistance output represents a resistive load.

In one switching period, this converter has five modes of operation [3]. This operation mode describes the working principle of converter topologies. In a simplification to facilitate understanding, it is assumed that the DC voltage input on the topology of a DC source which is fixed. The loads are resistors and all of diodes and the switches are in an ideal condition.

At  $t_0-t_1$ , switch  $S_1$  is on, magnetizing inductance ( $L_m$ ) charged by the voltage input ( $V_{in}$ ). Magnetization current gradually rise linearly. In this mode, resonant circuit is work. Resonant circuit formed by the secondary of the hybrid transformer,  $C_c$ ,  $L_r$ ,  $D_r$  dan  $C_r$ . In this mode, the clamping capacitor ( $C_c$ ) assumed in fully charged condition. secondary side Voltage of the transformer is  $n \times V L_m$ . Resonant capacitor ( $C_r$ ) charged by the secondary of transformer and clamping voltage on the capacitor ( $C_c$ ) by the switch, diode resonance and inductor resonance.

At  $t_1-t_2$ , with  $S_1$  is off. Current on the primary side and secondary side of the transformer began to charge the parasitic capacitor located on the switch. When the voltage on the switch is higher than the voltage on clamping capacitor ( $C_c$ ) then clamping diode ( $D_1$ ) is on. Energy from leakage inductance ( $L_k$ ) is transmitted to the clamping capacitor ( $C_c$ ) through the clamping diode ( $D_1$ ).

At  $t_2-t_3$ , in this period diode output ( $D_o$ ) is on. At this time a series circuit formed between  $V_{in}$ ,  $V_{lk}$ ,  $V_{Lm}$ ,  $V_{L2}$ ,  $V_{cr}$  dan  $V_{co}$ . The stored energy in the magnetizing inductance ( $L_m$ ) and a resonance capacitor ( $C_r$ ) forwarded to the load. Clamping diode ( $D_1$ ) stay active for clamping capacitor ( $C_c$ ) is charging.

At  $t_3-t_4$ ,  $D_1$  is off. The current flow to the output side during this period, but the magnitude is reduced gradually. The stored energy in the magnetizing inductance and resonance capacitor ( $C_r$ ) be forwarded simultaneously to the load.

At  $t_4-t_0$ , switch  $S_1$  is on. Because of the effects of leakage of hybrid transformer, output current ( $I_o$ ) keep flow for a short time, then a diode output is off at  $t_0$  and the next switching period begins again.

The value of conversion ratio determined by this following equation (14).

$$M = \frac{V_o}{V_{in}} = \frac{(2+n)}{(1-D)} \quad (14)$$

Voltage stress on switching and clamping diode ( $D_1$ ) happened on operation mode 1 ( $t_0-t_1$ ) and operation mode 2 ( $t_1-t_2$ ). Whereas, the value of voltage stress on diode output ( $D_o$ ) dan resonance diode ( $D_r$ ) can be seen at operation mode 1 ( $t_0-t_1$ ) dan operation mode 3 ( $t_2-t_3$ ).

$$V_{DS} = V_{D1} = V_{Cc} = \frac{V_{out}}{(n+2)} \quad (15)$$

$$V_{D_o} = V_{D_r} = V_o - V_{Cc} = \frac{(n+1)V_o}{(n+2)} \quad (16)$$

Resonant period and resonant frequency of converter determined by (17) and (18) equation.

$$T_r = 2\pi \sqrt{L_{r\_tot} C_r} \quad (17)$$

$$f_r = \frac{1}{T_r} \quad (18)$$

In implementation, leakage inductor value ( $L_k$ ) of transformer should be calculated.  $L_{kp}$  is leakage inductance of primary side and  $L_{ks}$  is leakage inductance of secondary side.

$$L_{r\_tot} = L_r + (L_{ks} + n^2 L_{kp}) \quad (19)$$

$$\Delta V_{Cr} = \frac{I_{Lm\_sec} T_{off}}{2C_r} \quad (20)$$

$$I_{Lm\_sec} = \frac{I_o}{1-D} = \frac{P_o}{V_o} \frac{1}{1-D} \quad (21)$$

$\Delta V_{Cr}$  shows the value of voltage ripple on resonance capacitor.  $I_{Lm\_sec}$  is the magnetization current average referenced from the secondary side of the transformer.

$$\Delta i_{Lr} = \pi f_r T_s I_o \quad (22)$$

$\Delta i_{Lr}$  shows the value of current on resonance inductor.

### III. ANALYSIS OF DESIGN CONFIGURATION

#### A. Design of Multistage Converter

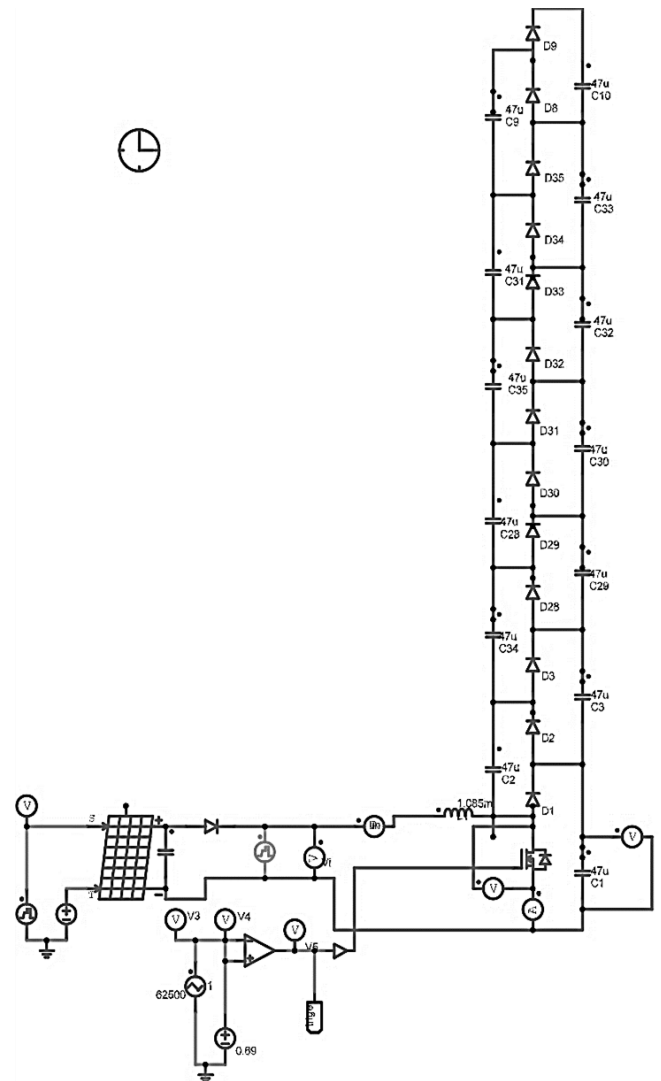

Figure 3. Simulation of Multistage Converter



5 Voltageinput (MAX) 30 V

To produce output voltage of 400 volts, it is necessary to adjust the duty cycle. The duty cycle is influenced by the size comparison of the input voltage and the output voltage at a ratio converter. In the converter hybrid transformers, to get the output voltage of 400 volts, the parameters are changed only duty cycle and input voltage. While the value of L and C others remain. In multistage converter, to get the output voltage of 400 V, the parameters modified are duty cycle, input voltage, and inductance values.

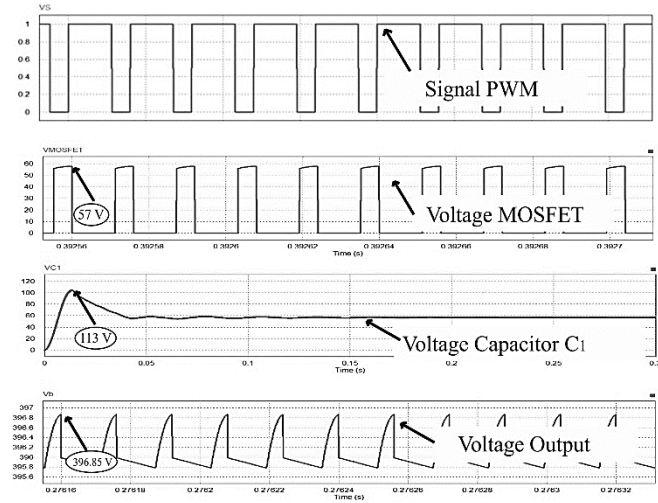

Figure 5. The voltage wave form of Multistage Converter Simulation

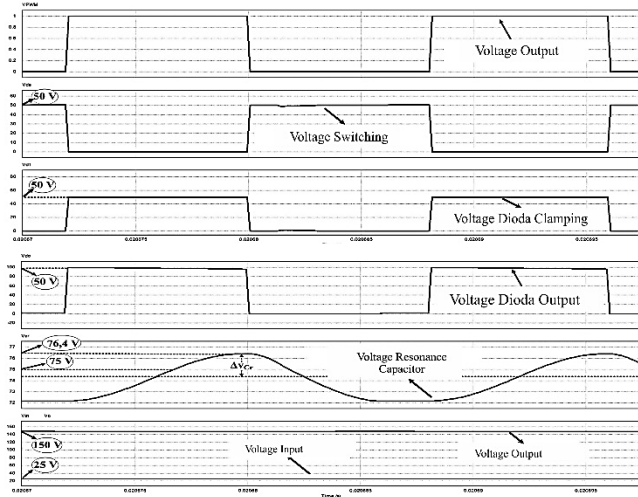

Figure 6. The Voltage wave form of High Boost Ratio Hybrid Transformer DC-DC simulation

Table 1, Table 2, and Figure 7 show that the converter transformers hybrid capable of producing a minimum efficiency of 88% when given input voltage 21 volts. However, the resulting maximum efficiency of 101.7% when given an input voltage of 30 V. The converter multistage can produce a minimum efficiency of 97.84% at an input voltage of 22 V and 23 V. The resulting maximum efficiency of 98.07% with an input voltage of 25 V.

Table 2. Comparison between the input voltage and Duty Cycle

Vin (V) Vout (V) Pout (Watt) Ro (Ω) D

Vin (V)	Vout (V)	Pout (Watt)	Ro (Ω)	D
20	400	50	3200	0.60
21	400	50	3200	0.58
22	400	50	3200	0.56
23	400	50	3200	0.54
24	400	50	3200	0.52
25	400	50	3200	0.50
26	400	50	3200	0.48
27	400	50	3200	0.46
28	400	50	3200	0.44
29	400	50	3200	0.42
30	400	50	3200	0.40

Table 3. Comparison between the input voltage and efficiency

Vin (V)	Hybrid Transformer			Multistage Converter		
	Vout (V)	Iout (A)	Efficiency (%)	Vout (V)	Iout (A)	Efficiency (%)
20	398	0.124	99.2	396	0.123	98%
21	375	0.117	88	395	0.123	97.96
22	389	0.121	94	395	0.123	97.84
23	398	0.124	99.18	395	0.123	97.84
24	398	0.124	99.14	395	0.123	97.88
25	398	0.124	99.23	396	0.123	98.07
26	397	0.124	98.94	396	0.123	98
27	397	0.124	98.76	395	0.123	97.98
28	397	0.124	98.76	396	0.123	98.06
29	397	0.124	98.62	395	0.123	98
30	403	0.126	101.7	396	0.123	98.06

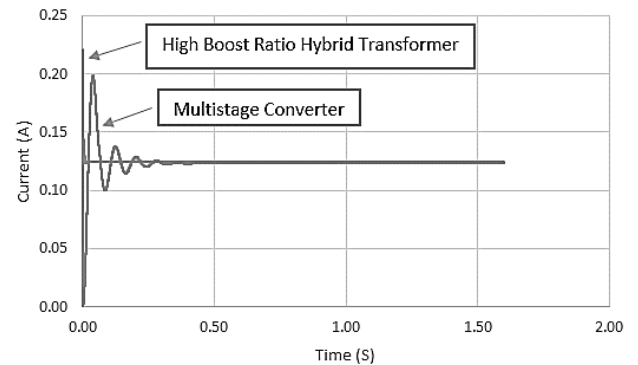
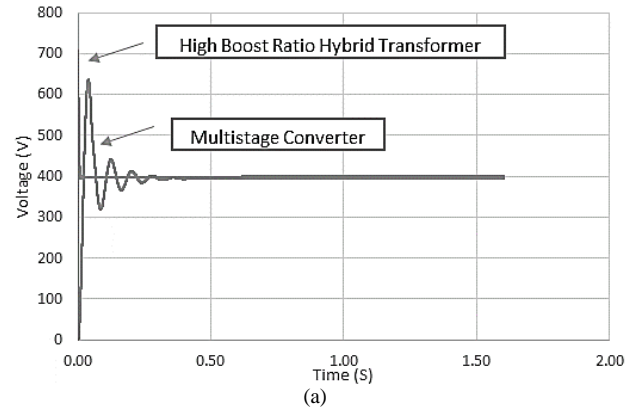

(b)

Figure 7. Comparison of Voltage wave form (a) and Current wave form (b) between Simulation of High Boost Ratio Hybrid Transformer DC-DC and Multistage Converter

#### V. CONCLUSION

1. The output voltage *High Boost Ratio Hybrid Transformer DC-DC Converter* can attain steady state more rapidly than multistage converter.
2. The same Duty cycle and voltage input, *High Boost Ratio Hybrid Transformer DC-DC Converter* method can produce output power greater than multistage converter.
3. The boost converter circuit with *High Boost Ratio Hybrid Transformer DC-DC Converter* had a high conversion ratio in this research. The rate conversion can be increased easily by raising the value of transformer winding ratio (n).
4. *High Boost Ratio Hybrid Transformer DC-DC Converter* can operate on a wide range of input voltage.

- [1] Q. Zhao and F.C. Lee, "High efficiency, high step-up dc-dc converter", IEEE trans. Power Electron., vol. 18, no. 1, pp. 65-73, Jan. 2003.
- [2] R.J. Wai and R.Y. Duan, "High step-up converter with coupled-inductor", IEEE Trans. Power Electron., vol. 20, no. 5, pp. 1025-1035, Sep. 2005.
- [3] Bin Gu, J. Dominic, J. S. Lai, Z. Zao and C. Liu, "High Boost Ratio Hybrid Transformer DC-DC Converter for Photovoltaic Module Applications", IEEE Transactions On Power Electronics, Vol. 28, No. 4, April 2013.
- [4] S. Cuk, "Step-down converter having a resonant inductor, a resonant capacitor and a hybrid transformer", U.S. Patent 7 915 874, Mar.2011.
- [5] S. Cuk and Z.Zhang, "Voltage step-up switching dc-to-dc converter field of the invention", U.S. Patent 7 778 046, Aug.2010.
- [6] M. S. B. Ranjana, N. S. Reddy and R. K. P. Kumar, "Non-Isolated Dual Output Hybrid DC-DC Multistage Converter for Photovoltaic Applications", International Conference on Devices, Circuits and Systems, 2014.